

**AMC SPIRIT, PACER, CONCORD,
CJ-5, CJ-7, CHEROKEE, WAGONEER
and PICK-UP V-8**

- 304 - 360 CUBIC INCH
- WITH OR WITHOUT POWER STEERING
- WITH OR WITHOUT AIR PUMP

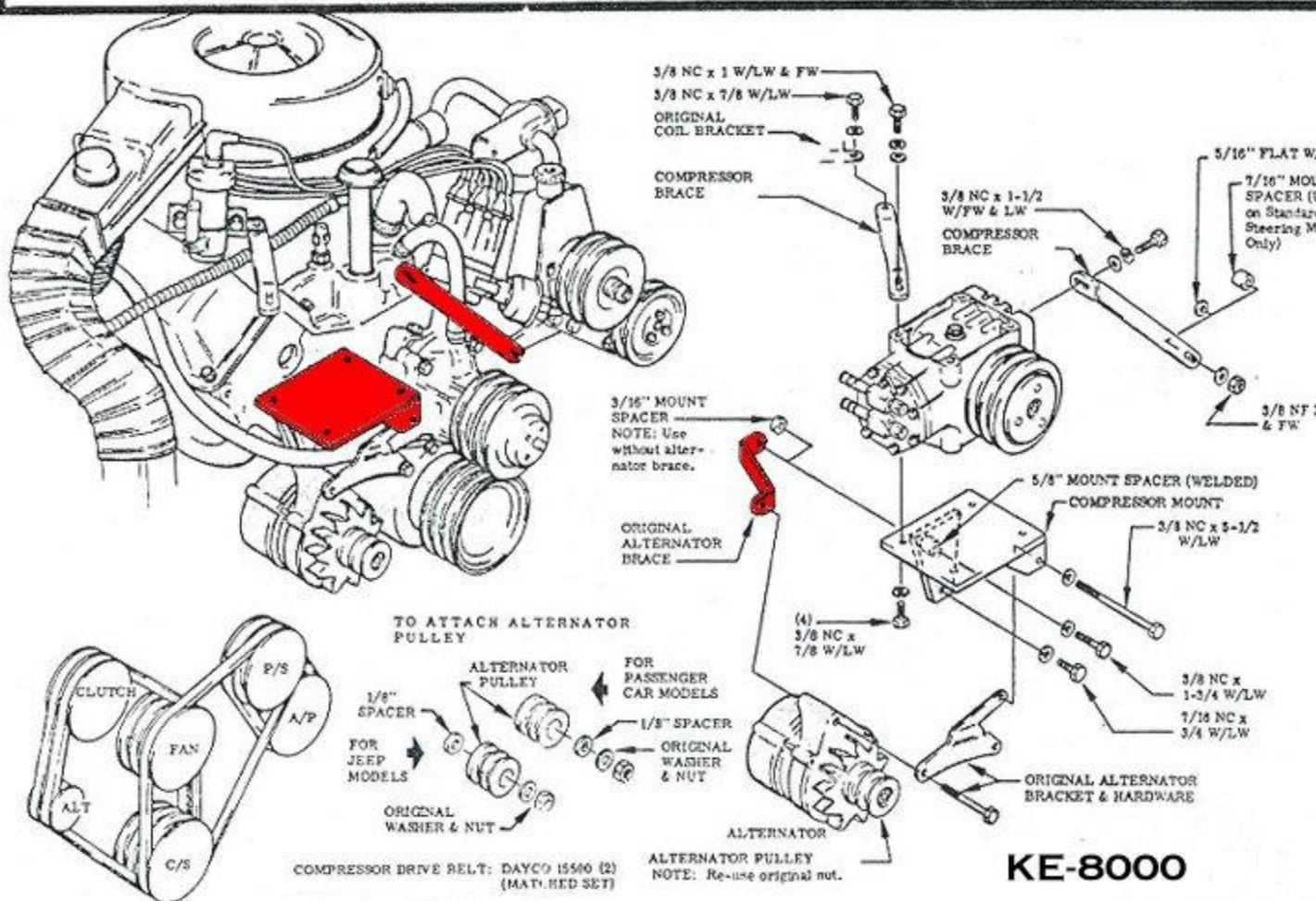

DESCRIPTION	QUANTITY	DESCRIPTION	QUANTITY
8000-1 Compressor Mount	1	3/8 NC x 1 3/4 Bolt-Hex Hd.	1
8000-2 Compressor Brace	1	3/8 NC x 5/2 Bolt-Hex Hd.	1
8000-3 Compressor Brace	1	7/16 NC x 3/4 Bolt-Hex Hd.	1
Alternator Pulley	1	3/8 NF Nut	1
3/16" Mount Spacer	1	3/8" Lockwasher	9
7/16" Mount Spacer	1	7/16" Lockwasher	1
1/8" Pulley Spacer	1	5/16" Flatwasher	1
3/8 NC x 7/8 Bolt-Hex Hd.	5	3/8" Flatwasher	3
3/8 NC x 1 Bolt-Hex Hd.	1	15500 (Dayco) Drive Belt	2
3/8 NC x 1 1/2 Bolt-Hex Hd.	1		

INSTALLATION INSTRUCTIONS

1. Disconnect battery. Drain and remove radiator. Remove factory fan assembly and discard alternator belt.
2. Remove and discard single groove alternator pulley and key if equipped. Install furnished alternator pulley using 1/8" spacer in front of pulley for all passenger cars or behind pulley for all Jeeps and replace original washer and nut.
3. Install mount assembly as follows:
 - a. Securely fasten compressor to compressor mount. Install compressor mount on engine.
 - b. Install compressor brace to engine locating coil and bracket on top of brace. Fasten to compressor.
 - c. Install side compressor brace using 5/16" flatwasher between power steering bracket and brace. Use 7/16" spacer only for standard steering models.
4. All above assembly bolts should now be uniformly tightened to prevent strain or misalignment.
5. Install coil then clutch and condenser.
6. Replace factory fan assembly. Thread belts as shown in schematic. Adjust each belt to proper tension and tighten all bolts securely.
7. Replace radiator and add coolant. Connect battery.